

MX 32

1- OR 2-CHANNEL CONTROLLER



EASY TO INSTALL

- Small-sized wall-mounted box
- Protected front face
- Sealed polycarbonate box (IP 65)
- Power supply 230 VAC or 115 VAC (24 VCC back-up)

VARIETY OF CONNECTIONS

- Wheatstone bridge detectors
- 4-20 mA transmitters (2 or 3 wires)
- Flame detectors

Oldham has designed the MX 32, a measurement and alarm unit that is perfectly suitable for the protection of your equipment and personnel in atmospheres which may contain flammable and toxic gases. Available with one or two separate channels, the MX 32 offers you tailor-made detection capabilities and exceptional programming possibilities with its range of Oldham detectors.

Its purchase and operating costs are enhanced by its easy installation and great operating flexibility.

- 1 or 2 independent channels
- 2 independent instantaneous alarm thresholds
- Fault alarm per channel
- Compliant with European Standards ATEX II (2) G

SIMPLE OPERATION

- Liquid crystal display panel
- Simple programming by keypad
- "Power on" indicator lights
- Visual alarms
 - 2 red LED for gas alarm thresholds per channel
 - 1 yellow LED for fault alarm per channel
- Buzzer
- Manual or automatic acknowledgement

CERTIFICATIONS



ATEX

The Fixed Gas Detection Experts

MX 32 1- OR 2-CHANNEL CONTROLLER

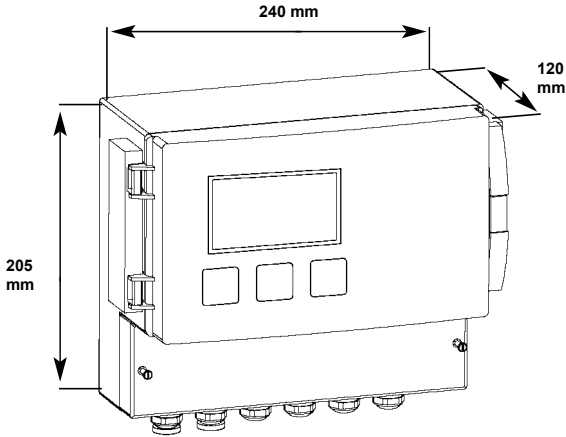

TECHNICAL SPECIFICATIONS	
Enclosure	Size (W x H x D): 240 x 205 x 120 mm - wall-mounted box
	Weight: 1.750 g
	Material : ABS
	Mounting: by DIN Rail supplied Protection: IP65
Display	Liquid crystal, fixed or scrolling
Power Supply	Voltage: 230 or 115 V AC and 21 to 31 V CC
	Consumption: 30 VA
Operating Temperature	-10°C to +45°C continuously
	14°F to +113°F continuously
Cabling (LiCY type)	Bridge type: • 1 detector: maximum distance 300 m (3 x 1 mm ²) • 2 detectors : please consult us
	Detector with transmitter: • One to five 2-wire detectors, 4-20 mA • One 3-wire detector, 4-20 mA • Cable 3 x 1.5 mm ² (32 Ω max. in loop mode)
	Flame detector: • Cable 3-wire, shielded, 3 x 1.5 mm ² (4.8 Ω max. in loop mode)
	Default: • Complete control on measuring line • Yellow LED fault per channel • Report on common relay
Alarms	Alarm: • 2 independant alarm thresholds per channel (Red LED) • Manual or automatic aknowledgment • Individual programming, by increasing or decreasing
	Audio alarm: • Buzzer, follows the default and alarm sequence
	Relays: • 2 independent gas alarm relays per channel (positive security, negative on demand) • 1 common relay for faults (positive security on default) • Breaking capacity 440 VA - 30 W • NO or NF, programmable by jumpers
Relative humidity	5 to 95% RH
Certifications	ATEX 94/9/CE Directive complies with EN 50054, EN 50057, EN 50104 and EN 50271 (61779-1:2000 and 61779-4:2000 standards)
	Category: Ex II (2) G
	Electromagnetic Compatibility: EN 50270 : 06 Types 1 and 2 Low Voltage Directive: EN 61010-1 : 10

